

PEDOTEC

POWER METER



USER GUIDE

TABLE OF CONTENTS

- CHAPTER 1 POWER METER Installation
- CHAPTER 2 Installation and Removal
 - a. Tension Adjustment
- CHAPTER 3 Pairing
- CHAPTER 4 Calibration and manual zero
- CHAPTER 5 Battery replacement
- CHAPTER 6 Firmware
- CHAPTER 7 Precautions
- CHAPTER 8 Warranty
- CHAPTER 9 WARRANTY CONTINUED

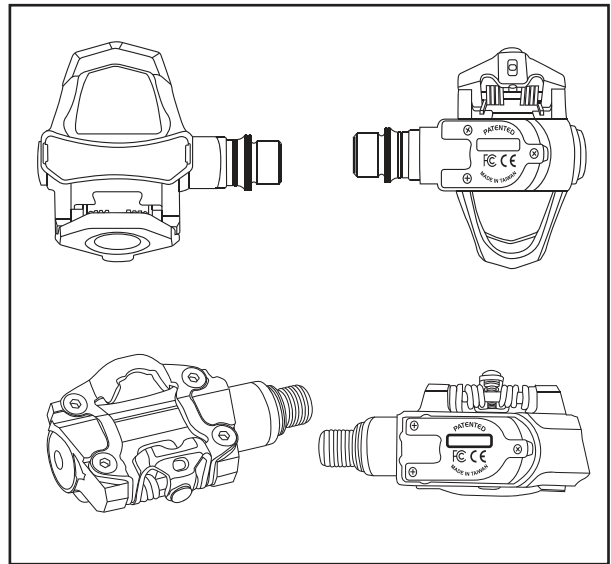

CHAPTER 1: POWER METER INSTALLATION

PACKAGE CONTENTS

1. Right pedal
2. Left pedal
3. Cleats (pair)
4. Cleat mounting hardware
5. Batteries (CR2032)
6. Pedal Identification Card (not pictured)

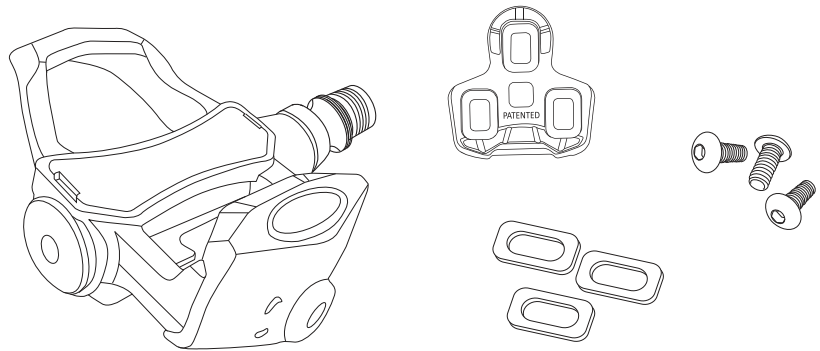

CHAPTER 2: INSTALLATION AND REMOVAL

PEDAL INSTALLATION

Note: FORMULA P-PEDAL series do not have flats on the pedal axle. A 6mm hex key must be used to secure pedal to the crank.

Before installing the pedals apply a light coat of grease to the threads on the axle. To install the right pedal thread the RIGHT pedal into the drive side crank arm. The drive side crank arm has a right-handed thread. Using the 6mm hex, turn the axle clockwise when viewed from the pedal side of the crank. Tighten the pedal to the torque specification recommended by the crank manufacturer. To install the left pedal thread the LEFT pedal into the non-drive side crank arm. The non-drive side pedal has a left-handed thread. Using the 6mm hex, turn the axle counter-clockwise when viewed from the pedal side of the crank. Tighten the pedal to the torque specification recommended by the crank manufacturer.

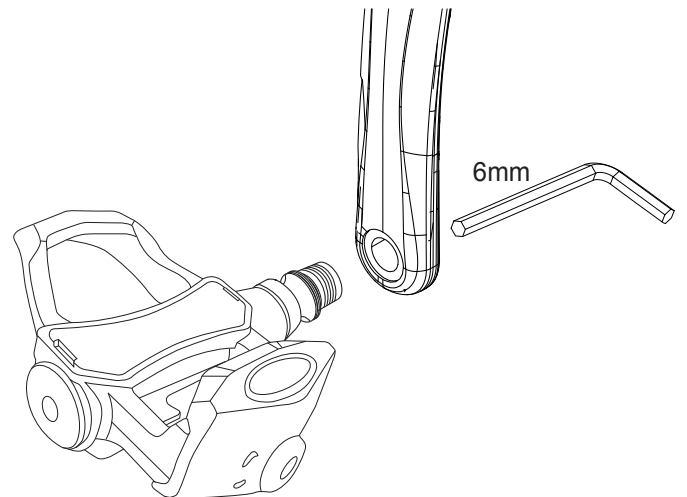

CLEAT INSTALLATION

Note: FORMULA P-PEDAL series must be used with the included cleats. They are compatible with LOOK KEO System only.

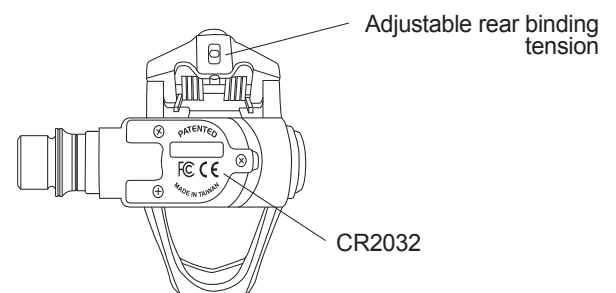

Setting the cleats to cycling shoes, use a 4 mm Allen key. Tightening torque: 50-80kgf/ cm (43-69 lb-in). Depending on the model of your pedals, the tension adjuster is located on the rear binding, or on the top of the pedal body. To adjust rear binding tension, use a 3 mm Allen key to turn tension adjuster. Binding adjustment value: 80-140kgf/ cm (69-121 lb-in). 1. Increase tension in a clockwise direction (+) (for a more secure shoe/pedal bind, but more difficult engagement and disengagement). 2. Decrease tension in a counter-clockwise direction (-) (for less secure shoe/pedal bind but easier engagement and disengagement). Engage cleated shoes in the pedals by aligning the cleat between front and rear bindings while pushing down. Disengage by twisting heel outwards (away from bicycle). The Cleat will also release by twisting heel inwards if necessary (for emergency situations only). If you have never used clip-in pedals before, take time to learn how to use them safely. Make sure the tension adjuster is set to the lowest setting. Sit on, or stand over your bike with one foot firmly on the ground. With the other foot, practice engaging and disengaging cleated shoe. When you get used to this, progress to riding slowly in a safe, traffic-free area until engagement and disengagement become natural actions that you can manage easily without looking at your feet. Warning Binding tension should be equal on both pedals to achieve a uniform effect when engaging and disengaging cleated shoes. Minimum tension is recommended for beginners and for rides requiring frequent cleat disengagement, such as in heavy traffic. Do not over-tighten or over-loosen tension adjuster (over tightening may damage thread, and bolt may fall out if too loose).

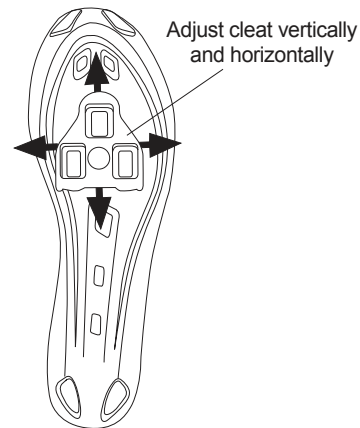
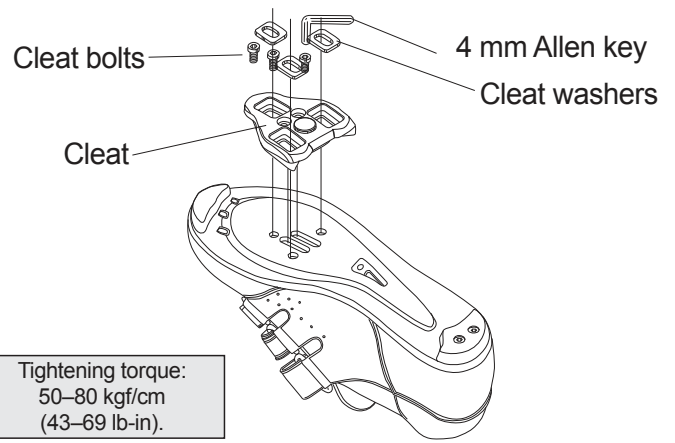

Note: Cleats need to be replaced periodically based on individual rider use. If cleats are showing signs of wear or are not engaging and disengaging from the pedal replace them in a timely manner.

CHAPTER 3: PAIRING

PEDAL SLEEP AND WAKING

After 20 minutes without moving the pedal goes to sleep to conserve battery life. Wake the pedal up by spinning the pedal several times.

PAIRING

Bluetooth : It will have two signals from left and right pedals.

ANT+ : It will have one signal from PEDOTEC Power Meter pedals

And for pairing the user just have to use one way to connect the pedal will do

To pair:

1. Awake both pedals by spinning them a few times individually. Upon awaking the green LED will illuminate. Then the green LED will blink when functioning normally.
2. Go to the SENSORS screen on your display and select POWER SENSOR from the menu and initiate the pair. Note: this can take up to a few seconds.
3. When the ID from the appropriate sensor shows on the display screen select this sensor by pressing the ENTER button. Then activate the sensor. (ANT+ ID>ACTIVATE SENSOR)

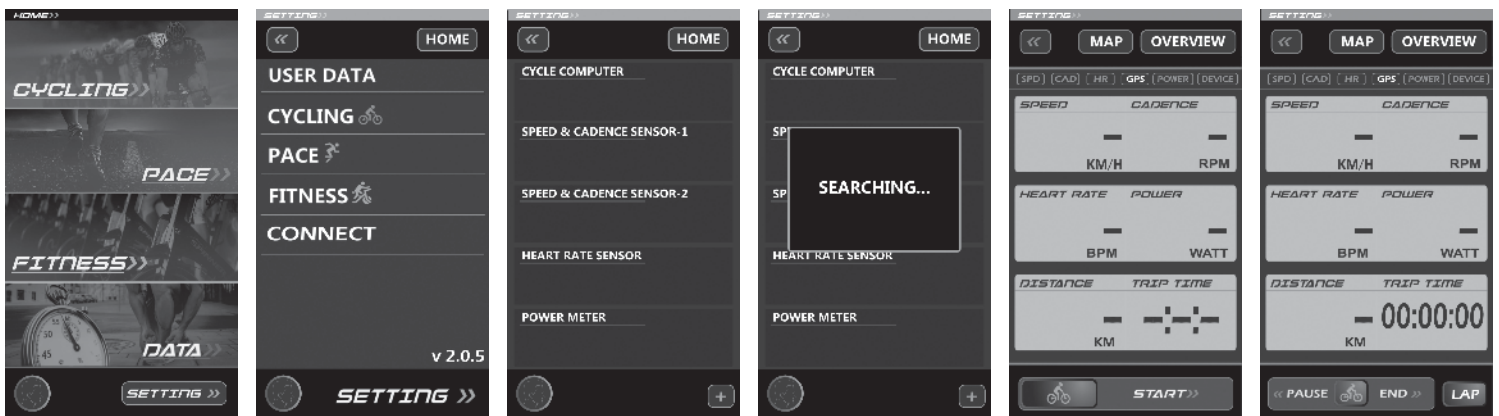

Bluetooth SMART and ANT+ - The pedal broadcasts data using Bluetooth Smart and ANT+ simultaneously. You can pair your pedal to any device using either of these wireless protocols.

Remark:

1. When using Bluetooth will have two signals for the power meter. The Bluetooth will receives the left side only.
2. The left pedal is main to receive the software update.
The left pedal sends the update to the app.

Bluetooth Smart 

Bluetooth Smart is the low energy version of Bluetooth wireless technology. Learn more about this technology visit www.bluetooth.com

ANT+ 

ANT+ is a low energy form of wireless technology used in many sport electronics. To learn more about ANT+ visit www.thisisant.com

CHAPTER 4: CALIBRATION AND MANUAL ZERO

FORMULA P-PEDAL series is dynamically calibrated from the factory to the highest standard.

About calibration and manual zero the setting way, when calibrating and pairing the FORMULA P-PEDAL series with two sensors, start by rotating the pedals to the highest point of the crank rotation starting from the left pedal, then follow by the right pedal to calibrate and pair with your power computer or phone app. Or please followed the cycling computer brand to setting.

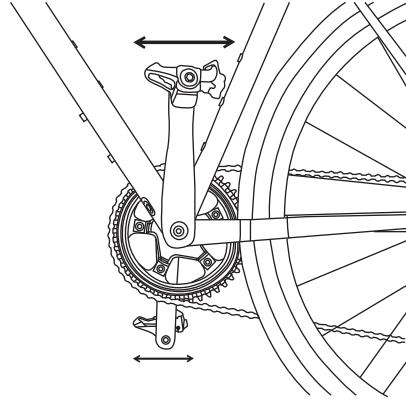

CHAPTER 5: BATTERY REPLACEMENT

BATTERY REPLACEMENT

To replace the battery use a phillipscrewdriver to remove the battery cover. Replace battery in clean/dry conditions. Remove old battery if necessary and replace with new battery. Reference underside of pedal for correct battery orientation. Reinstall battery cover but do not overtighten.

The batteries damage created by human is not covered under the warranty of the pedals. Remove batteries from the pedal system if they will be unused for longer than a half year. Use only CR2032 3V lithium batteries with the pedal system.

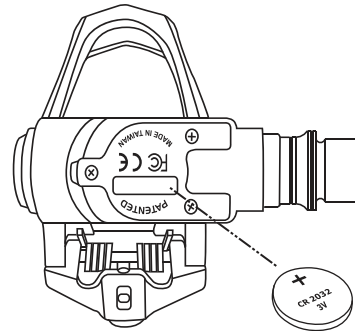

CHAPTER 6: FIRMWARE

FIRMWARE UPDATES

Firmware on the pedals can be updated wirelessly when new firmware releases are available. To enjoy the full capabilities of the FORMULA P-PEDAL series Pedals including ongoing enhancements and Over-the-Air firmware updates you must download Rider for life App from the App Store.

To check for/or perform over the air (OTA) firmware update follow the steps below.

Bluetooth must be turned “on” on

- 1) Your iOS / Android device
- 2) Bluetooth must be turned “on” in the PTM app (see switch “Use BLE”; BLE= Bluetooth Low Energy).

CHAPTER 7: PRECAUTIONS

PRECAUTIONS

Avoid submerging pedals in water and direct high pressure water spray. Damaging chemicals like diesel, kerosene and other strong solvents will also potentially cause damage to the product.



WARNING: Keep the pedals away from strong magnets.

Some of the electronics inside the pedal are sensitive to strong magnets and if your pedals come in close contact with strong magnets they may begin transmitting abnormal data.

CHAPTER 8: WARRANTY

OFFICIAL WARRANTY TERMS

APMS's warranty policy is to warranty all parts against defects and craftsmanship. This does not include wear or abuse. Warranted for a period of one year from the date of invoice. Please retain your invoice for your records as proof of purchase will be required. If the item is unsure a warranty or not, please contact APMS with photos and information. If the vendor confirmed the products have any problems through factors created by human, the repair fee and return shipping fee need pay through distributor.

CHAPTER 9: WARRANTY CONTINUED

Any product or part thereof found to be defective within the term as set forth above will be replaced without charge provided that: (1) its failure resulted from a defect in material or workmanship and not from normal wear and tear expected in the use of the product; (2) the product was not misused, improperly assembled, improperly maintained or damaged by accident; (3) there was no failure to follow instructions or warnings in the Owner's Manual.

APMS reserves the right to inspect any product before issuing a replacement. APMS's only obligation shall be to replace such products or parts that it determines are defective.

LIMITATIONS

The foregoing warranties are in lieu of and exclude all other warranties not expressly set forth herein, whether expressed or implied by operation of law or otherwise. Other than as set forth above, APMS makes no warranty, whether express, implied or statutory, with respect to any product, including, but not limited to, warranties of reliability, merchant ability fitness for a particular purpose, or those arising from any course of performance, dealing, usage or trade.

APMS shall not be liable for incidental or consequential losses, damages or expenses in connection with its products. APMS's liability hereunder shall be expressly limited to the replacement of goods not complying with this warranty or, at APMS's discretion, to the repayment of the purchase amount of the product in question. Some states do not permit the exclusion or limitation of implied warranties or incidental or consequential damages, so the preceding limitations and exclusions may not apply.

FCC STATEMENT

This device complies with Part 15 of the FCC Rules. Operation is subject to the following two conditions: (1) This device will not cause harmful interference, and (2) This device may accept certain interference that may cause undesired operation.

The warranty policy will not be responsible for any changes or modifications not expressly approved by the party responsible for compliance. Such modifications could void the user's ability to operate the equipment within its normal functionality.

This equipment has been tested and found to comply with the limits for a Class B digital device, pursuant to part 15 of the FCC Rules. These limits are designed to provide reasonable protection against harmful interference in a residential installation. This equipment generates and uses radio frequency energy to function. If the equipments are not installed and used in accordance with the instructions provided, it may cause interference to other radio frequency devices. However, there is no guarantee that this interference will or will not occur during the use of our products. If this equipment does cause harmful interference to radio or television reception, which can be determined by turning the equipment off and on, the user is encouraged to try to correct the interference by one or more of the following measures:

- Reorient or relocate the receiving antenna. —Increase the separation between the equipment and receiver.
- Connect the equipment into an outlet on a circuit different from that to which the receiver is connected.
- Consult the dealer or an experienced professional for help.

IC Statement

This device complies with Industry Canada licence exempt RSS standard(s). Operation is subject to the following two conditions: (1) this device may not cause interference. (2) this device must be able to accept interference, including interference that may cause undesired operation of the device.